



Installation Instructions for Fortress Fe²⁶ Railing Traditional Adjustable Panels with Universal Brackets and Iron Posts

It is the responsibility of the installer to meet all code and safety requirements, and to obtain all required building permits. The deck and railing installer should determine and implement appropriate installation techniques for each installation situation. The Fortress Company nor its distributors shall not be held liable for improper or unsafe installations.

Fortress Fe²⁶ Posts must always be secured to the deck framing. Fortress Iron Posts should never be attached to only the deck boards.

Read Instructions Completely Before Starting Installation

Note

When cutting Fortress railing, it is very important to complete the following at cut points. Not following the below steps will result in rust at the cut areas:

- Remove all metal shavings from the cut area
- File any sharp edges left by cutting. Thoroughly wipe and remove any filings, grime or dirt from the railing.
- Apply two coats of Fortress zinc based touch-up paint to the cut area. If touch up is at rail ends, allow paint to dry before connecting bracket to post.
- Be sure to remove any metal shavings from the surface of deck, patio or balcony to prevent rust on the surface.

Required Materials

UB-04, UB-04 Angle Kit, Drill, 5/32" Drill Bit, Phillips Head Screw Driver, T-25 Driver Bit, Metal Cutting Saw, Tape Measure, Wrenches, Pencil, Speed Square, Center Punch, Support Blocks, Clamps and Hammer.

Fe²⁶ Traditional Adjustable Panels

Fe²⁶ Traditional Adjustable Panel 8' (actual length 93.5")
Available Heights 34" and 40"
Maximum rake angle 45°

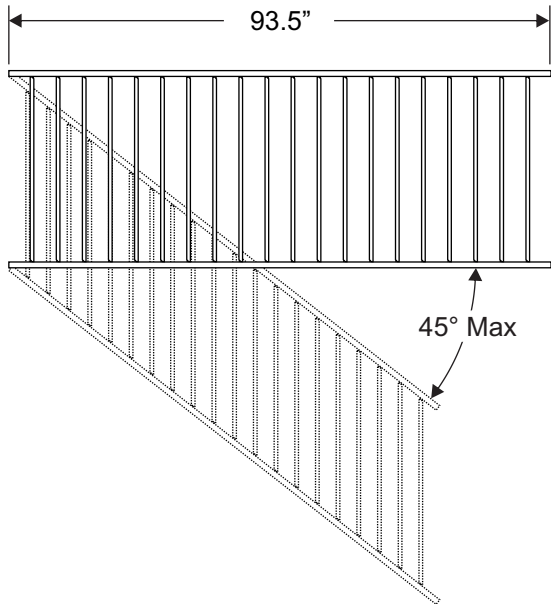

Fe²⁶ Traditional Adjustable Panel 6' (actual length 72")
Available Heights 34" and 40"
Maximum rake angle 45°

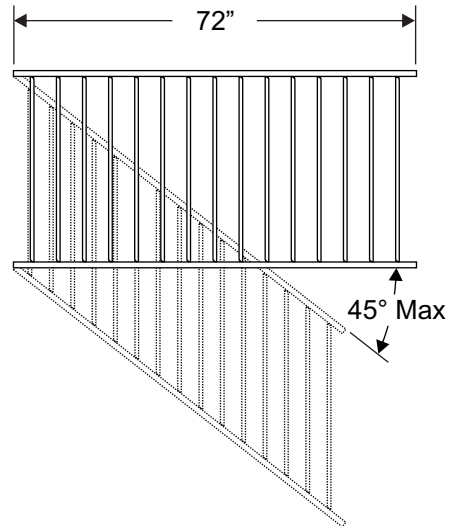

Important - Every stair installation will be different. The rise and run, post position, and post height all need to be carefully laid out before posts are permanently installed and Fortress Fe²⁶ Traditional Adjustable panels are cut.

Mount Iron Posts*

- Wood Blocking tied to deck frame must be installed and constructed with treated dimensional lumber with a minimum thickness of 1/1/2".
- Position the edge of post base plate a minimum of 1/2" from the inside edge of rim joist.
- Mount posts at appropriate points based on panel length.
- Attach Iron posts with 3/8 X 3-1/2" Hex Head Galvanized Bolts.

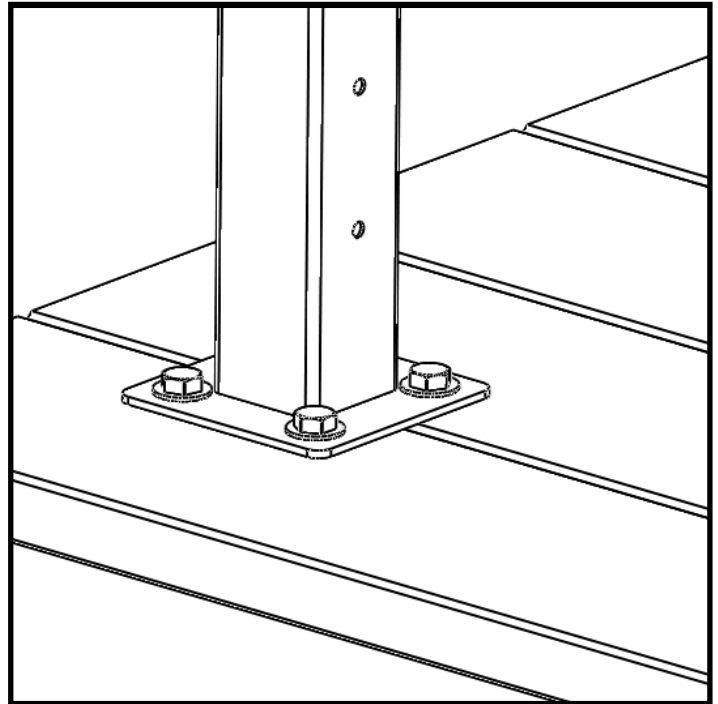
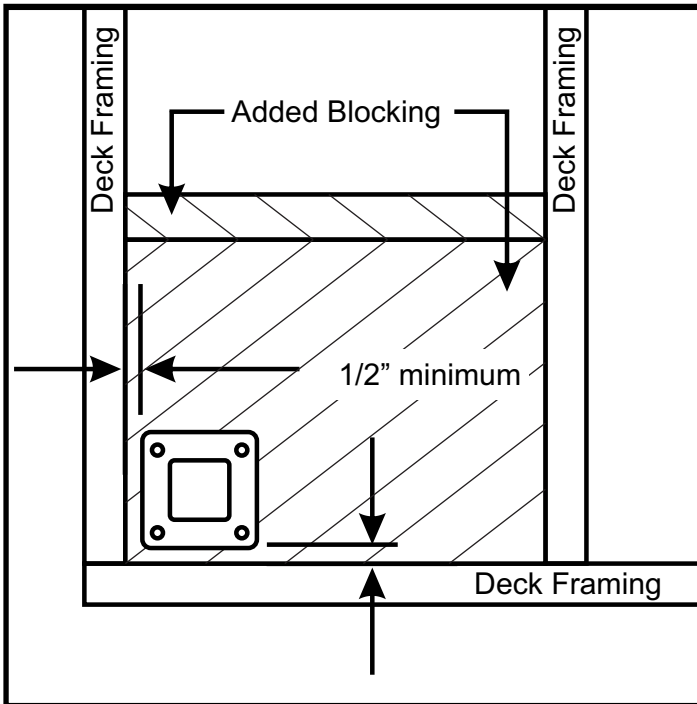

*Reference Fortress iron post mounting instructions

Determine Rake and Center Panel Between Posts

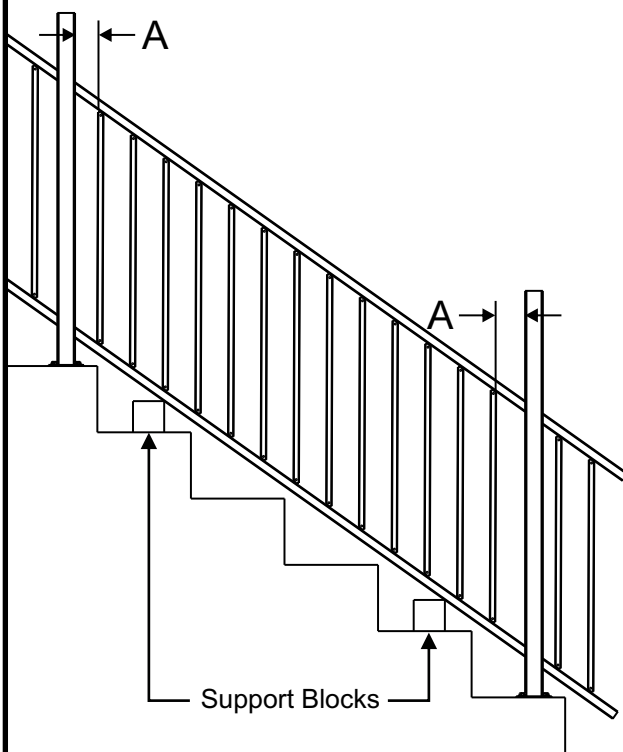

Use Fe²⁶ Adjustable Panel to determine the angle of stair installation. To do this use support blocks resting on the stair tread. Position support blocks so that the position of the bottom rail meets the spacing requirement of your building code.

Rake the panel so that the balusters run parallel with the posts. Center the balusters so that there is a equal amount of rail between the post and baluster at each end (Dimension A).

Make sure that there is enough clearance between the post and first picket to allow for the bracket.

Mark location of support blocks.

Verify Panel Position and Secure with Clamps

- Verify the position of the panel. With the help of another person, secure the panel into the correct position and secure with clamps at each end of panel.
- Place a piece of cardboard between the clamping surfaces and the surfaces of the rails and posts to protect the finish.

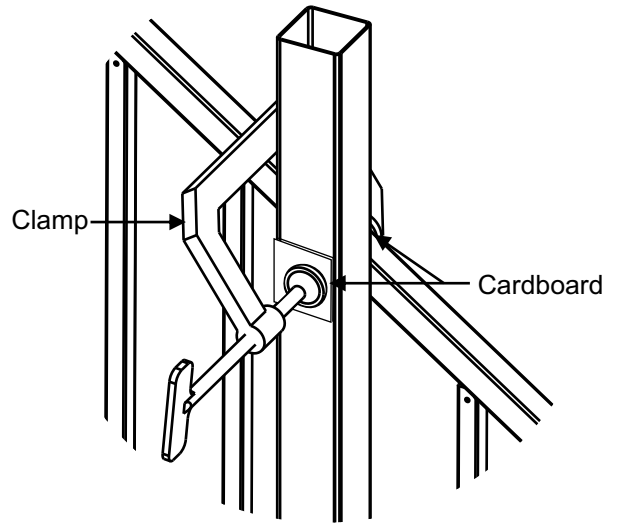
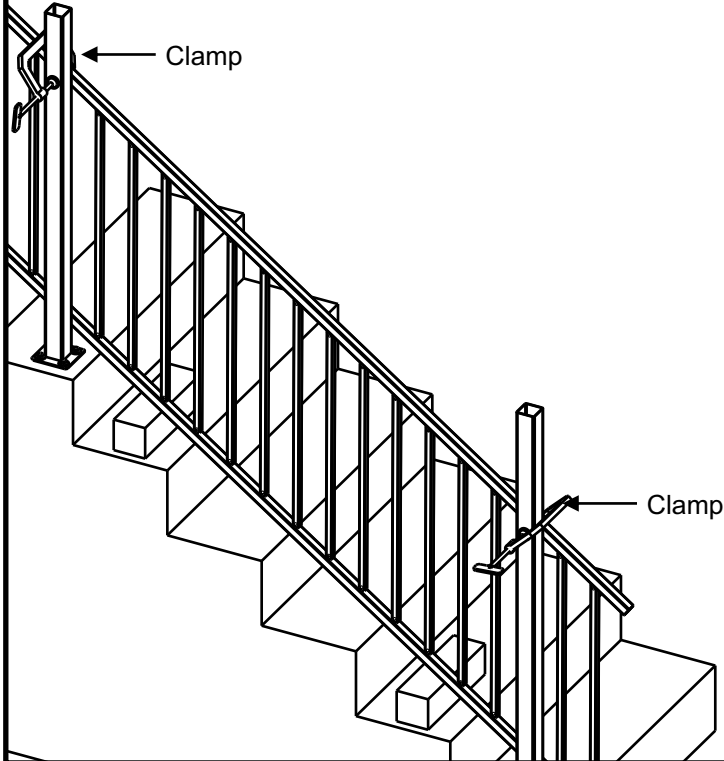

Assemble Universal Bracket Angle Kit Assembly and Mark Rail Length

- Assemble the Universal Bracket Angle Kit Assembly to the Universal Bracket Cup with supplied screws. Do not over tighten hinge pin, as it will be temporarily removed in a later step.
- Place Universal Bracket Angle Kit against post and position the cup so that it is parallel to the rail. With a pencil mark the position where the rail meets the back wall of the UB Cup on the top of the rail. With bracket in the same position mark the hole locations of the Post Plate on the post. **DO NOT DRILL HOLES AT THIS TIME.**
- Repeat this step for all four Universal Bracket Angle Bracket Locations.

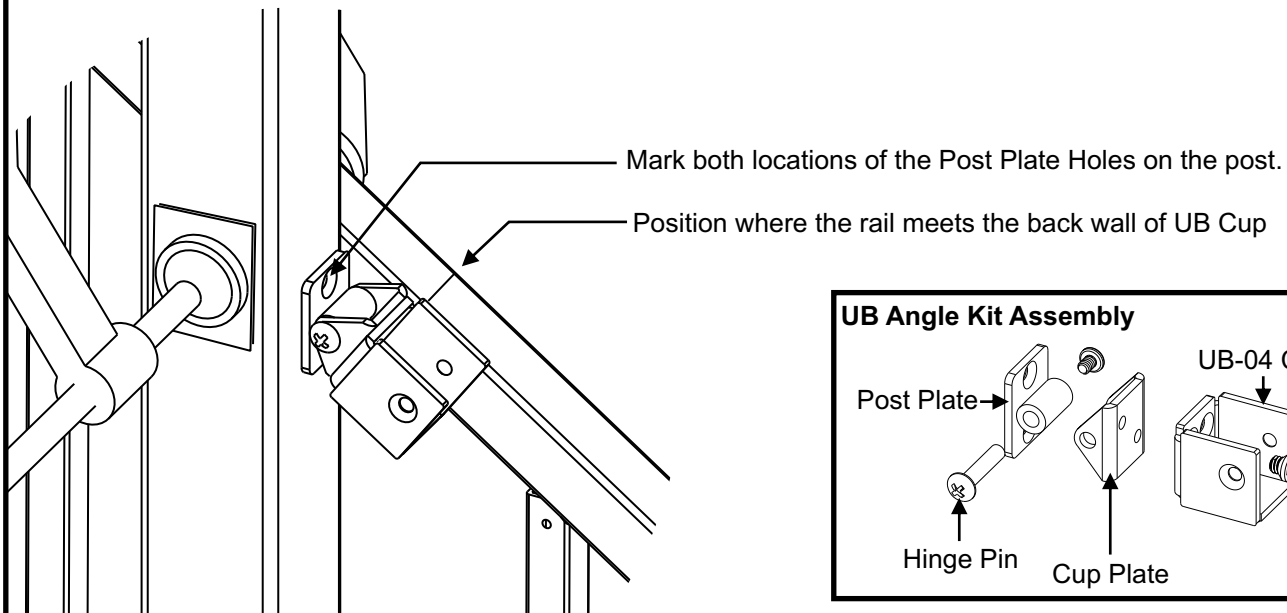

UB Angle Kit Assembly

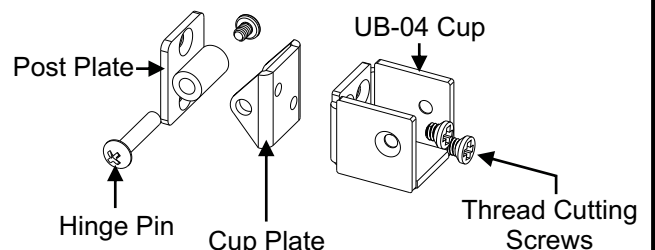

Pre-Drill and Install Universal Bracket Post Plates

- Remove c-clamps and panels.
- Mark the centerline of each post. The UB Brackets will be installed on the centerline, not the locations marked in the previous step.
- Use a center punch and hammer to mark the hole locations and pre-drill all bracket hole locations.
- Remove Hinge Pin from UB Angle Kit Assemblies.
- Attach UB Angle Kit Post Plates to post with supplied T-25 self drilling screws.
- Reassemble UB Angle Kit Assemblies with Hing Pins
- **Remove all metal shavings from deck, post base cover, post, and panel before bracket is screwed to post to prevent rust stains.**

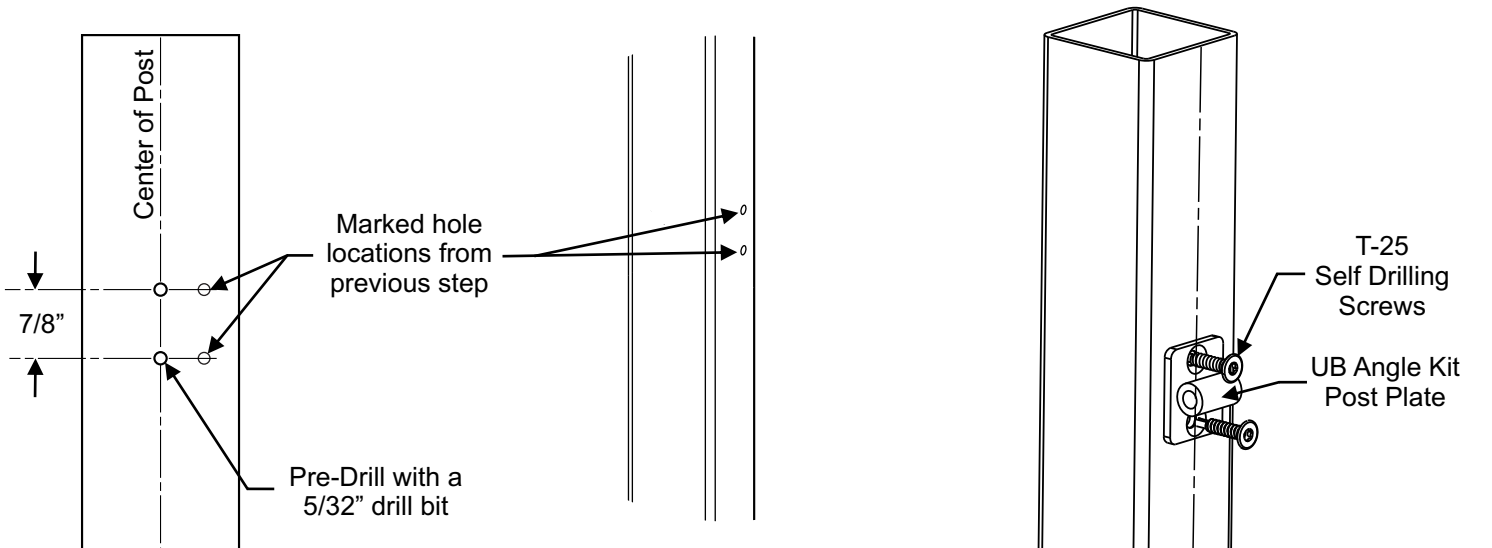

Cutting Fortress Fe²⁶ Railing Traditional Adjustable Panels

- Rake the panel back to 90° and lay on a flat surface.
- Using a metal cutting blade, cut the rail at the four cutting mark locations from previous step. It is advisable to make a practice cut on a scrap piece of rail before proceeding with the finish cuts.
- **The distances from the first picket to the ends of the rail, will be different from the top to bottom rail. The greater the angle of the steps the more visible the difference will be. This is required in order to keep balusters pickets parallel to the post.**
- File cut edges and coat with 2 coats of Fortress zinc based touch-up paint.

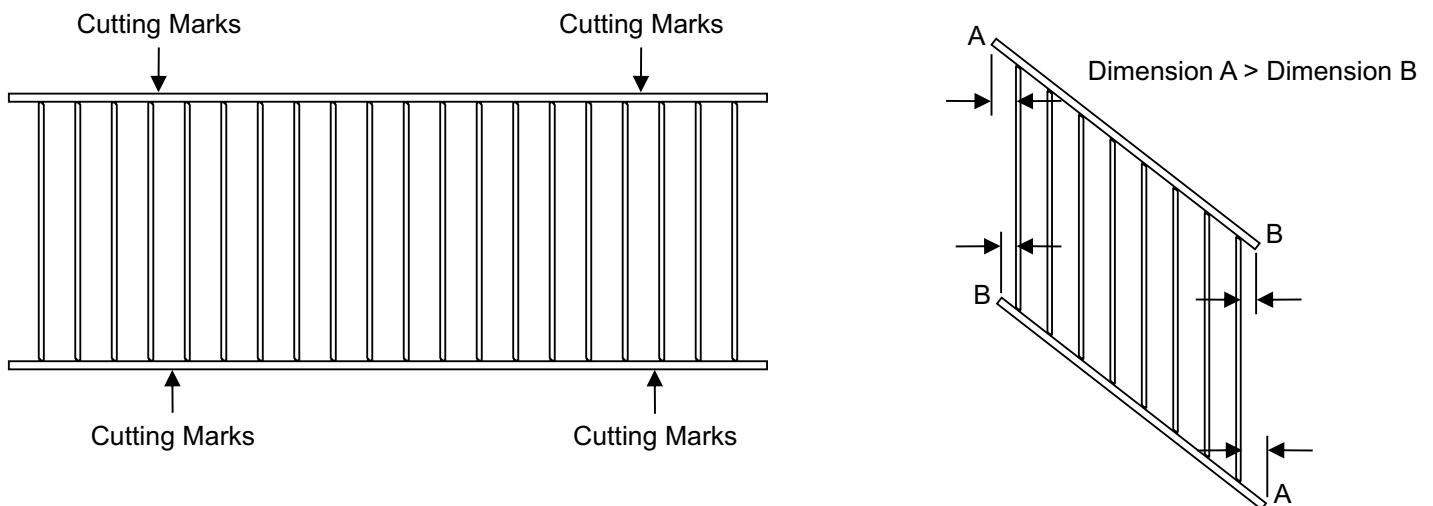

Install Panel

- Reposition support blocks.
- Position Panel so that it aligns with the brackets. Use a clamp to hold the panel in place.
- Check the fit of the panel and make any required adjustments.
- Secure panel with a set screw installed into each bracket.

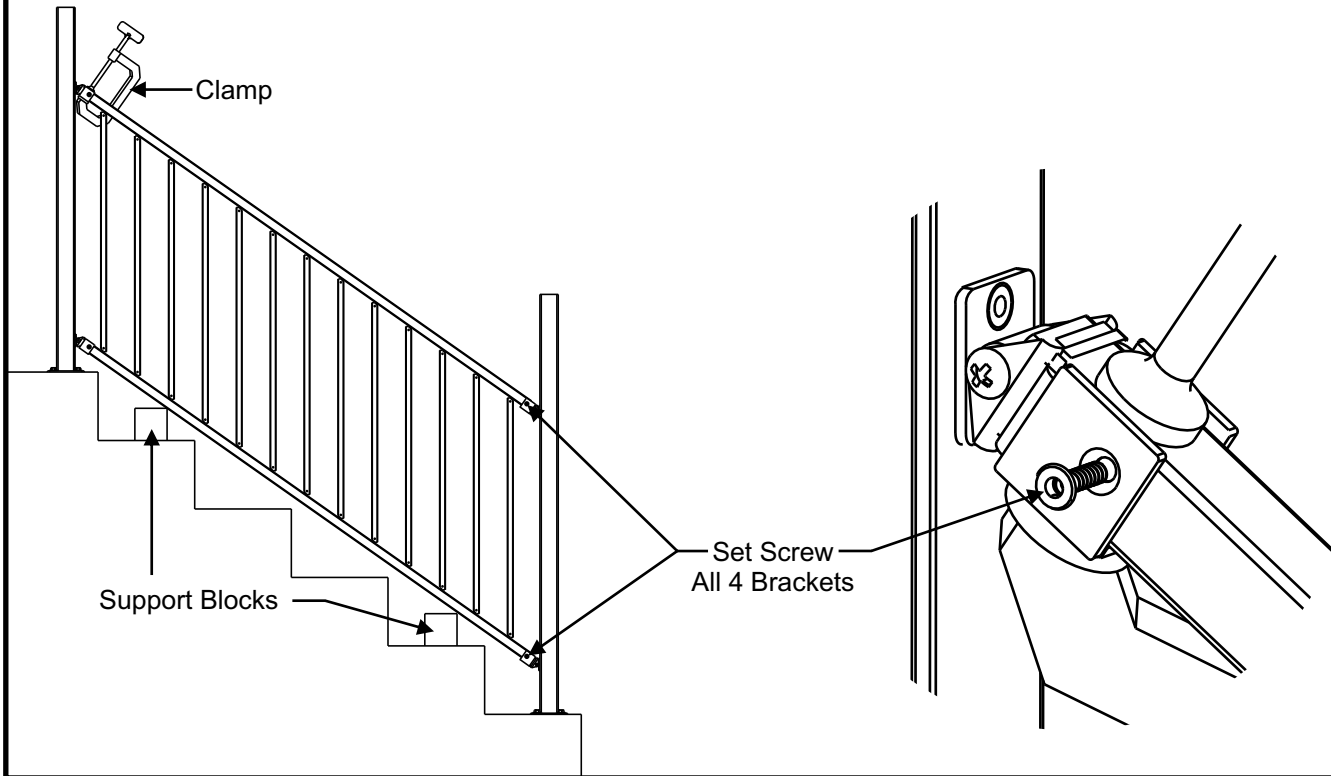

Install UB Caps

- Install UB caps by snapping the cap into place.

