



Installation Instructions FortressAccents LED Glow Ring with FortressAccents Post Caps

It is the responsibility of the installer to meet all code and safety requirements. The installer should determine and implement the appropriate installation techniques for each situation. The Fortress Company or its distributors shall not be held liable for improper or unsafe installations.

WARNING – Risk of Electric Shock. Install all luminaires 10 feet (3.05 m) or more from a pool, spa, or fountain.

Required Materials: Phillips Head Screw Driver, Wire Cutters, Wire Strippers, Eye Protection

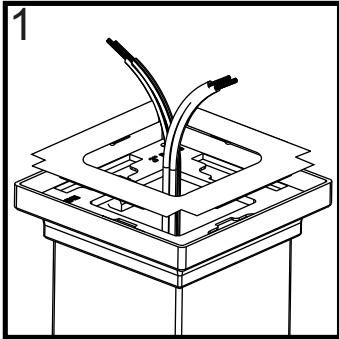

1. Run 18-2 gauge stranded outdoor wire (available from FortressAccents, please visit www.fortressaccents.com for dealer locations) by routing in close proximity to the luminaire or fitting, or next to a building structure such as a house or deck. Wire should not be buried. Install FortressAccents post cap base to post. FortressAccents post cap installation will vary depending on style of post. Remove light plugs from FortressAccents post cap base.

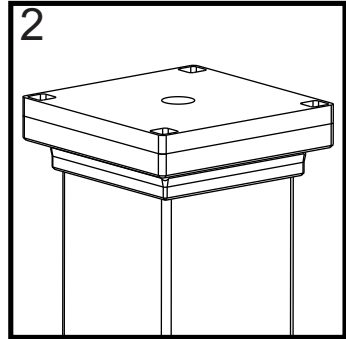

2. Protect edges of LED Glow Ring lens from scratching during installation. Check the fit of LED Glow Ring into the FortressAccents post cap base. Bottom edge of LED Glow Ring lens will sit flat on the top edge of post cap base. If there is a gap, adjust the screws that hold the post cap base to the post to allow for proper fit of LED Glow Ring lens.

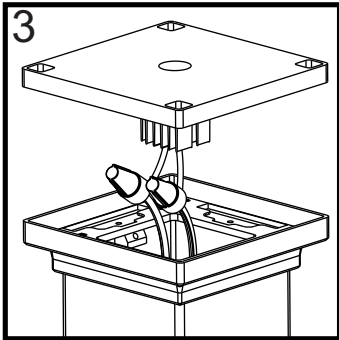

3. Remove the LED Glow Ring lens from post cap base. Strip the wire insulation back $\frac{1}{2}$ " from the field wiring. Connect wires with provided waterproof wire nuts. Wire connections can also be made below the deck surface. Note: Polarity must be maintained. Always connect the same side of 18-2 gauge wire with the same polarity (i.e. positive) marked on the LED Glow Ring.

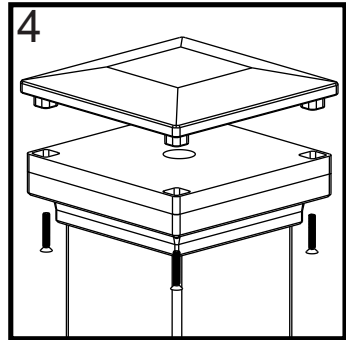

4. Before installing the post cap, recheck the fit of the LED Glow Ring on to the post cap base. Connect the field wiring to the transformer and turn on the lights to verify that the wiring is correct. Align the post cap screw bosses with the holes located at each corner of the LED Glow Ring Lens. Install the post cap cover with the fasteners provided with the LED Glow Ring.

Please visit www.fortressaccents.com for information on how to order additional accessories.

For technical assistance, please email: technicalhelp@fortressrailing.com
Hours of Operation Monday through Friday 8:00 AM to 5:00 PM CST
Phone: 1-866-323-4766 Fax: 972-644-3720
www.fortressaccents.com